

# GRAPHICAL MODEL-BASED TRACKING OF CURVILINEAR STRUCTURES IN BIO-IMAGE SEQUENCES

Pradeep Koulgi, Mehmet Emre Sargin, Kenneth Rose and B. S. Manjunath \*

*Department of Electrical and Computer Engineering, University of California Santa Barbara, USA*  
 {pradeep, msargin, rose, manj}@ece.ucsb.edu

## Abstract

*Tracking of curvilinear structures is a task of fundamental importance in the quantitative analysis of biological structures such as neurons, blood vessels, retinal interconnects, microtubules, etc. The state of the art HMM-based contour tracking scheme for tracking microtubules, while performing well in most scenarios, can miss the track if, during its growth, it intersects another microtubule in its neighbourhood. In this paper we present a graphical model-based tracking algorithm which propagates across frames information about the dynamics of all the microtubules. This allows the algorithm to faithfully differentiate the contour of interest from others that contribute to the clutter, and maintain tracking accuracy. We present results of experiments on real microtubule images captured using fluorescence microscopy, and show that our proposed scheme outperforms the existing HMM-based scheme.*

## 1. Introduction

With the advent of powerful microscopes and high-resolution image capturing equipment, it has now become possible to capture enormous amounts of images and data of biological specimen and phenomena. Manual inspection and analysis of data of such magnitude by a trained human expert is practically impossible. Hence developing computational algorithms to automate the task of data analysis has become a very important and challenging task [1]. In this paper we focus on images of microtubules in live cell images, captured using fluorescence microscopy, and propose a graphical model-based open contour tracking algorithm for tracking these microtubules. While existing microtubule tracking algorithms [1], [2] is prone to missing tracks

in the presence of high clutter from other microtubules in the vicinity, our algorithm is designed to overcome the clutter and successfully track the contour.

Microtubules are filamentous subcellular structures that are composed of tubulin protein sub-units. These sub-units, by adding on to and dissociating from the tubulin polymer, make the microtubules grow and shorten over time. They are also capable of slight lateral motion over time, making them highly dynamic structures. They are known to play a significant role in many essential cellular processes [4]. Figure 1 shows a sample image of microtubules.

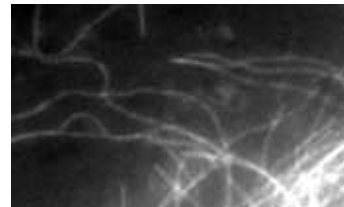

**Figure 1. Microtubules imaged using fluorescence microscopy.**

The problem of reliably tracking microtubules has been addressed in the literature in the past. In [2], microtubule tips are tracked using a graph matching algorithm, and then entire body is traced using active contours with the tracked tip as the anchor point. But this algorithm can be sensitive to the accuracy of tip detection, upon which the active contour-based body-tracing is dependent. Another approach described in [3] matches microtubule tips by correlating with a feature corresponding to the tip. Another application of curvilinear tracking is in blood vessel extraction, a survey of which can be found in [6].

More recently, an HMM-based tracking algorithm was proposed in [1] which uses a deformable trellis to track the microtubule body. The deformable trellis elegantly accounts for both length as well as shape vari-

\*This study was funded by Center for Bio-image Informatics under the grant NSF III-0808772.

ations of the microtubules. But with this algorithm, if the microtubule being tracked intersects another microtubule during its growth/shortening phases, the estimated contour track tends to miss the actual track of the microtubule of interest, depending on the angle of intersection. This is mainly because, the extension of the trellis in the new frame to account for the microtubule’s growth depends mainly on the evidence for existence of microtubule beyond its tip (as estimated in the previous frame). Note that this does not take into account whether such evidence comes from growth of the microtubule of interest or from another one in the vicinity. This ambiguity can be overcome by propagating across frames the temporal information about the activity of the cluttering microtubules as well, and this is the chief motivation for our proposed work.

In our algorithm, we propose to use a graphical model to formulate the problem of estimating microtubule positions as a multi-class probabilistic pixel labeling problem. We propagate across frames the posterior probabilities of locations of all the microtubules, and the track of the microtubule of interest is estimated only on the pixels having significant probability of belonging to the microtubule of interest, thereby maintaining tracking accuracy.

## 2 Methodology

In this section we present our algorithm to track curvilinear structures in the presence of clutter induced by other similar-looking structures in the near vicinity. The algorithm uses the estimated contour position in the previous frame as prior information for the current frame and employs a factor graph to elegantly combine it with information from the current frame.

We formulate the problem of estimating the positions of microtubules as a 3-class probabilistic pixel labeling problem using a factor graph-based graphical model. We define the joint probability distribution function of pixel labels as being factored into functions which capture the unary and binary-interaction potentials, which in turn represent the priors and likelihoods, respectively. We perform statistical inference on this factor graph using belief propagation to obtain *a posteriori* marginal probabilities of the labels at each pixel. A constrained optimization-based tracing method similar to the one described in [5] is used on the probability maps to trace the entire body of the microtubule on each frame. Figure 3 shows an outline of the algorithm.

### 2.1 Factor Graph Formulation

Let us consider an image  $I$  containing more than one curvilinear structure. One of these would be the structure of interest to be tracked, in the presence of the others in the near vicinity. Let there be  $M$  pixels in  $I$ , and let  $x_i$  represent the label of the  $i^{th}$  pixel, with  $\mathcal{L} = \{l_{CoI}, l_{BgC}, l_{Bg}\}$  denoting the set of labels corresponding to “contour of interest” ( $l_{CoI}$ ), “other contour” ( $l_{BgC}$ ) and “background” ( $l_{Bg}$ ).

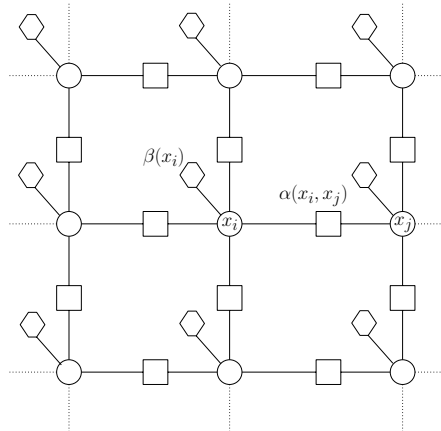

**Figure 2. Illustration of our graphical model. The circles represent pixels while squares and hexagons denote the factors capturing the pair-wise interaction and unary potentials, respectively**

The factor graph employed in our algorithm is illustrated in Figure 2. Each pixel in the image  $I$  corresponds to a node in the graph, represented by circles, their unary and binary interaction potentials being represented by hexagons and squares, respectively. Then the joint pdf  $p(\mathbf{x})$  of all the pixels taking their respective labels can be written as

$$p(\mathbf{x}) = \frac{1}{Z} \prod_{i=1}^M \beta(x_i) \prod_{m=1, n \in N_m}^M \alpha(x_m, x_n) \quad (1)$$

where  $N_m$  represents the neighbourhood of pixel  $m$ , in the 4-connected neighbourhood sense, and  $Z$  is the normalizing factor. The function  $\alpha(x_i, x_j)$  captures the pair-wise interaction between neighbouring pixels  $i$  and  $j$  while  $\beta(x_i)$  denotes the unary potential at pixel  $i$ .

#### 2.1.1 Prior and Likelihood Probabilities

The unary potential function  $\beta(x_i)$ , defined to depend only on the pixel location, is assigned the prior proba-

bility of observing label  $x_i$  at that location, i.e.,

$$\beta(x_i) = p^-(x_i). \quad (2)$$

where  $\beta(x_i)$  is derived from posterior marginal probabilities computed on the previous frame, and in the first frame, is initialized using user input on the contour of interest.

The binary potential  $\alpha(x_i, x_j)$  is defined as the likelihood of having labels  $x_i$  and  $x_j$  at pixels  $i$  and  $j$  respectively. Supposing that  $o_{ij}$  is a feature measuring the of evidence supporting the labels at locations  $i$  and  $j$ , we define  $\alpha(x_i, x_j)$  as

$$\alpha(x_i, x_j) = p(o_{ij}|x_i, x_j) \quad (3)$$

The probabilities  $p(o_{ij}|x_i, x_j)$  for all  $i$  and  $j$  are obtained from the foreground (i.e., contour) and background models that are learnt offline on an image on which the ground truth is known.

We choose the feature  $o_{ij}$  as the average second order directional derivative in the direction perpendicular to the line joining pixels  $i$  and  $j$ , i.e.,

$$o_{ij} = \int_0^1 f((1-\tau)i_x + \tau j_x, (1-\tau)i_y + \tau j_y, \theta) d\tau \quad (4)$$

where  $[i_x \ i_y]^T$  and  $[j_x \ j_y]^T$  are the cartesian coordinates of pixels at locations  $i$  and  $j$ , respectively. The quantity  $f(i_x, i_y, \theta) = \mathbf{v}^T \mathbf{H}(i_x, i_y) \mathbf{v}$ ,  $\mathbf{v} = [\cos \theta \ \sin \theta]^T$  and  $\theta = \tan^{-1} \left( \frac{j_y - i_y}{j_x - i_x} \right) + \frac{\pi}{2}$ . The matrix  $\mathbf{H}(i_x, i_y)$  represents the Hessian evaluated on the image at the pixel location  $i$ . With  $o_{ij}$  as the feature of choice, we compute gaussian models for the foreground  $P(o|C)$  and background  $P(o|\bar{C})$ . The probabilities  $p(o_{ij}|x_i, x_j)$  for various combinations of  $x_i$  and  $x_j$  are computed simply by evaluating  $P(o|C)$  and  $P(o|\bar{C})$  for  $o = o_{ij}$ .

## 2.2 Statistical Inference and Track Estimation

With the factor graph defined as described above, we perform statistical inference on it using belief propagation. The *a posteriori* marginal probabilities thus obtained give the ‘best’ pixel labeling scheme, in a probabilistic sense.

We adapt the curve-tracing algorithm described in [5] and apply it to the probability map corresponding to the label  $l_{CoI}$ , i.e.,  $p(x_i = l_{CoI})$ . We propagate this trace incrementally along all possible directions, subject to the constraint that the candidate directions satisfy a threshold on the average probability on the probability map along the estimated local trace direction. Performing this operation on the probability map  $p(x_i = l_{CoI})$  ensures that the estimated microtubule track does not easily get distracted by intersection with another cluttering microtubule.

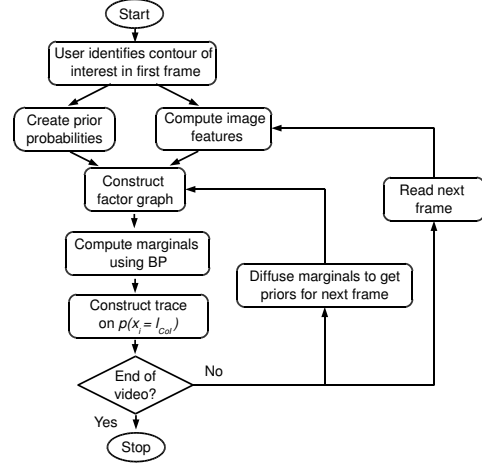

Figure 3. Proposed tracking algorithm.

## 3 Experimental Results

In order to validate our algorithm and show its improved tracking performance over the HMM-based tracking described in [1], we tested it on tracking of microtubules in real live cell images. The time-lapse images of microtubules were captured 4 seconds apart during their growth and shortening phases, each image sequence containing about 40 frames. The ground truth for the microtubule tracks were gathered by having experts manually track the microtubules using polyline approximations to the microtubule bodies.

A total of 25 microtubules were selected and tracked over their sequence. Tracking was considered successful if the tracked tip position was within 6 pixels (set by biologists) from that of the ground truth. With this as metric, the performance of our algorithm was found to be comparable to that of existing scheme in all the general cases. In about 10 % of the cases where microtubule of interest intersected with another, our scheme performed better than the existing scheme.

Figures 4 and 5 illustrate two cases where our algorithm performed better than the existing scheme. Figure 4 shows a microtubule that grows and intersects with another one. At the intersection, the existing HMM-based scheme misses the track of the microtubule of interest while the proposed algorithm successfully tracks it without getting distracted by the track of the neighbouring microtubule. Figure 5 illustrates another scenario where the microtubule grows and then shortens abruptly. The existing scheme mistakenly jumps to the track of the neighbouring one even though the microtubule of interest shortens before intersecting, while our proposed algorithm faithfully tracks it during both its growing and shortening phases.

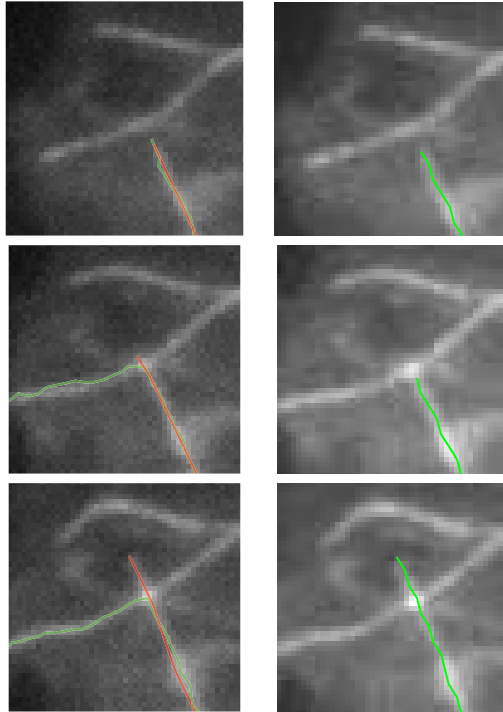

(a) HMM-based method (b) Proposed method

**Figure 4. Tracking a microtubule in its growth phase. Tracks estimated (green) using (a) the existing HMM-based method and (b) the proposed method. The ground truth is marked in red.**

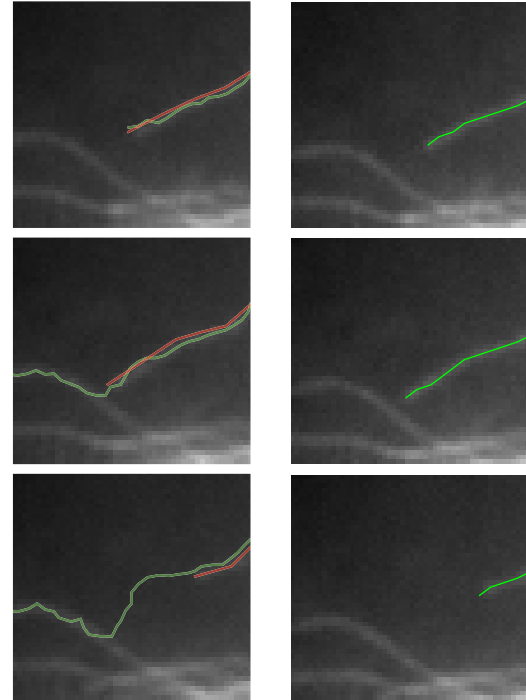

(a) HMM-based tracking (b) Proposed algorithm

**Figure 5. A microtubule growing and then shortening abruptly. Tracks estimated (green) using (a) the existing HMM-based method and (b) the proposed method. The ground truth is marked in red.**

## 4 Conclusion

In this paper we propose a graphical model-based contour tracking algorithm that is able to track contours even in the presence of intersections and clutter in the neighbourhood. The most noteworthy contribution of our work lies in casting the problem of locating the contours as that of estimating the best probabilistic pixel labeling scheme. This allows us to perform body-tracing of the contour only on pixels that have a high probability of lying on the contour of interest. Thus it avoids getting distracted by tracks of other contours in the near vicinity. Results of extensive experiments on tracking of microtubules in real images clearly bring out the advantages of our scheme.

## References

- [1] M.E. Sargin, A. Altinok, K. Rose and B.S. Manjunath, "Deformable Trellis: Open Contour Tracking in Bio-Image Sequences", *Proc. of IEEE ICASSP*, pp. 561-564, 2008.
- [2] A. Altinok, M. El-Saban, A. J. Peck, L. Wilson, S. Feinstein, B. S. Manjunath, and K. Rose, "Activity Analysis in Microtubule Videos by Mixture of Hidden Markov Models," *Proc. of IEEE Conf. on CVPR*, vol. 2, pp. 1662-1669, 2006.
- [3] S. Hadjidemetriou, D. Toomre, and J. Duncan, "Motion Tracking of the Outer Tips of Microtubules," *Medical Image Analysis*, vol.12, no. 6, pp. 689-702, 2008.
- [4] B. Alberts, A. Johnson, M. Raff and P. Walter, "Molecular Biology of the Cell," Garland Scientific, 4th edition, 2002.
- [5] M.E. Sargin, A. Altinok, K. Rose and B.S. Manjunath, "Tracing Curvilinear Structures in Live Cell Images", *Proc. of IEEE ICIP*, vol.6, pp. 285-288, 2007.
- [6] C. Kirbas and F. Quek, "A Review of Vessel Extraction Techniques and Algorithms," *ACM Computing Surveys*, vol. 36, no. 2, pp. 81-121, 2004.